

Real-Time Grain Storage Monitoring System

¹Suganda P, ²Roselin M, ³Manoj R R, ⁴Basavaraj C M, ⁵Manjunath B M, ⁶Rahul M R
^{1,2,3,4,5} ⁶Electronics and Communication Eng. Rural Engineering Collage Hulkoti

Abstract—Efficient storage of food grains is essential for maintaining food quality and reducing post-harvest losses. Improper storage conditions such as high temperature, humidity, and gas accumulation often lead to spoilage, fungal growth, and pest infestation. This paper presents the design and implementation of an IoT-based Smart Food Grain Storage Monitoring System that continuously monitors environmental conditions inside the grain storage unit. The system utilizes an Arduino Uno microcontroller integrated with DHT22 temperature and humidity sensors and MQ135 gas sensors to detect variations in environmental parameters that may affect grain quality. The collected data is displayed on an LCD module and warning indications are provided through LED alerts when parameters exceed predefined threshold values. The proposed system reduces manual monitoring efforts and helps farmers maintain proper storage conditions. The developed prototype demonstrates a cost-effective and reliable solution for small-scale grain storage facilities, enabling improved grain preservation and reduced post-harvest losses.

Keywords—IoT, Arduino Uno, Smart Grain Storage, DHT22 Sensor, MQ135 Gas Sensor, Automation.

I. INTRODUCTION

The Food grain storage plays a crucial role in ensuring food security and minimizing post-harvest losses. A significant portion of agricultural produce is lost due to improper storage conditions such as excessive temperature, humidity fluctuations, and gas accumulation inside storage containers. Traditional storage methods rely on manual inspection and periodic monitoring, which are inefficient and often fail to detect early spoilage conditions. With the advancement of Internet of Things (IoT) technology, it has become possible to develop intelligent monitoring systems capable of automatically tracking environmental parameters in real time. IoT-based monitoring systems allow farmers and storage facility operators to observe storage conditions continuously and take preventive action before damage occurs. This project proposes a Smart Food Grain Storage

Monitoring System that uses sensors and microcontroller technology to monitor the internal conditions of stored grains. The system measures temperature, humidity, and gas levels inside the storage container and provides alerts when abnormal conditions occur.

By integrating sensors with an Arduino

microcontroller, the system can efficiently monitor grain conditions and help prevent spoilage. The proposed system aims to provide a low-cost, automated, and reliable monitoring solution suitable for farmers and small-scale storage facilities.

II. LITERATURE SURVEY

[1] A. Singh and R. Verma proposed an IoT-based grain storage monitoring system to reduce food grain loss caused by improper storage conditions. The system uses sensors to monitor environmental parameters such as temperature,

humidity, and CO₂ concentration inside storage warehouses. The collected data is transmitted through a microcontroller and uploaded to a cloud platform for real-time monitoring. If the values exceed safe limits, the system alerts the user so that corrective action can be taken. This approach helps maintain proper storage conditions and reduces spoilage of grains during long-term storage. [2] U. Raut and S. Patil developed a sensor-based smart grain storage system that continuously monitors environmental conditions inside storage facilities. The system integrates sensors such as temperature, humidity, and gas sensors to detect unfavorable storage conditions that may lead to grain deterioration. The collected data is processed by a microcontroller and displayed to the user for monitoring. By maintaining optimal storage parameters, the system helps prevent damage caused by moisture, pests, and microbial growth, thereby improving the quality and shelf life of stored grains. [3] P. More and R. Kharde presented an IoT-based smart agriculture monitoring system designed to improve agricultural management using wireless sensor networks. The system collects environmental data such as temperature, humidity, and soil conditions using sensors connected to a microcontroller. The information is transmitted through the internet to allow farmers to monitor field conditions remotely. This technology enhances decision-making, reduces manual effort, and increases productivity in agricultural systems. [4] Suganda P and Roselin M proposed a smart grain storage system using IoT to monitor storage conditions. The system uses sensors to measure temperature, humidity, and gas levels inside the storage unit. The collected data is transmitted through the internet for real-time monitoring and alerts when conditions exceed safe limits, helping to reduce grain spoilage.

III. EXISTING SYSTEM

Traditional grain storage systems rely primarily on manual inspection to monitor grain conditions. Farmers or storage managers periodically check temperature, moisture, and pest infestation manually. This process is time-consuming and often inaccurate. In some advanced systems, sensors are used to monitor environmental parameters, but these systems may involve expensive equipment or complex communication modules. Additionally, many existing systems lack real-time monitoring and automated alert mechanisms.

The limitations of existing systems include:

- High cost of advanced monitoring equipment
- Lack of real-time monitoring capabilities
- Dependence on manual inspection
- Delayed detection of spoilage conditions

These limitations highlight the need for a simple and affordable monitoring system that can continuously observe storage conditions and provide timely alerts.



IV. PROPOSED SYSTEM

The proposed Smart Food Grain Storage Monitoring System is designed to automatically monitor environmental conditions inside a grain storage container. The system uses an Arduino Uno microcontroller as the central processing unit.

The following sensors are integrated in the system:

- **DHT22 Sensor** – Measures temperature and humidity inside the storage container.
- **MQ135 Gas Sensor** – Detects carbon dioxide and harmful gases that indicate grain spoilage.
- **LCD Display** – Shows real-time sensor readings.
- **LED Indicators** – Provide warning signals when environmental conditions exceed safe limits.

The sensors continuously collect environmental data and send it to the Arduino microcontroller. The microcontroller processes this data and displays it on the LCD screen. If abnormal conditions are detected, LED indicators alert the user. This automated monitoring system helps maintain safe storage conditions and reduces the risk of grain spoilage.

V. BLOCK DIAGRAM

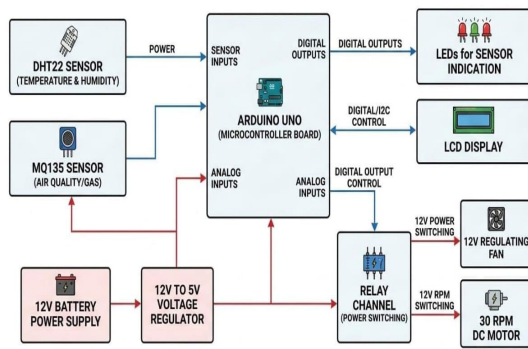

Fig. 1. Block Diagram

VI. WORKING PRINCIPLE

A The Smart Grain Storage System works by continuously monitoring the environmental conditions inside the grain storage unit using sensors connected to a microcontroller. The main controller used in the system is the Arduino Uno, which processes the data collected from different sensors. The DHT22 temperature and humidity sensor measures the temperature and humidity levels inside the grain storage area. If the temperature rises above the safe limit, the Arduino detects this change and activates a relay module, which automatically turns on the 12V fan to reduce the temperature and maintain a safe storage environment. The MQ135 gas sensor is used to detect harmful gases such as carbon dioxide that may form due to grain spoilage. When the gas level exceeds the predefined limit, the system triggers an LED indicator or buzzer to alert the user about possible grain deterioration. A 16×2 LCD display is used to show real-time values of temperature, humidity, and gas levels so that the user can easily monitor the storage conditions. The system can also send data to an IoT platform for remote monitoring. By automatically controlling ventilation and continuously monitoring environmental conditions, the system helps prevent grain spoilage, insect infestation, and moisture damage, ensuring better grain quality during storage.

VII. METHODOLOGY

The implementation of the smart grain storage system involves the following steps:

Hardware Setup:

All sensors, Arduino Uno, LCD display, and LED indicators are connected using a breadboard and appropriate wiring.

Sensor Data Collection:

The DHT22 sensor measures temperature and humidity, while the MQ135 sensor detects gas concentrations inside the storage unit.

Microcontroller Processing:

The Arduino Uno processes the data received from the sensors and compares it with predefined threshold values.

Display and Alerts:

Sensor readings are displayed on the LCD screen. If temperature or gas levels exceed safe limits, LED indicators provide visual alerts.

System Monitoring:

The system continuously monitors environmental parameters and helps maintain safe storage conditions.

VIII. HARDWARE IMPLEMENTATION

1. Arduino Uno

The Arduino Uno serves as the main controller of the system. It processes sensor data and controls the display and alert mechanisms.

2. DHT22 Sensor

The DHT22 sensor measures temperature and humidity levels. It provides accurate digital readings and is widely used in environmental monitoring applications.

3. MQ135 Gas Sensor

The MQ135 gas sensor detects harmful gases such as carbon dioxide, ammonia, and other volatile compounds that may indicate grain spoilage.

4. LCD Display

A 16×2 LCD display is used to show real-time sensor readings and system status.

5. LED Indicators

LEDs are used as warning indicators to alert users when unsafe storage conditions are detected.

IX. ADVANTAGES

The proposed system offers several advantages:

- Continuous monitoring of grain storage conditions
- Early detection of spoilage and harmful gases
- Reduced manual inspection efforts
- Low cost and easy implementation
- Suitable for small-scale farmers and warehouses
- Improved grain quality and reduced losses

X. CONCLUSION

The proposed IoT-based Smart Food Grain Storage Monitoring System successfully demonstrates an efficient and affordable solution for monitoring grain storage conditions. By integrating temperature, humidity, and gas sensors with an Arduino microcontroller, the system continuously tracks environmental parameters that influence grain quality. The developed prototype provides real-time monitoring and alert mechanisms that help prevent spoilage and reduce post-harvest losses. The system is simple, cost-effective, and suitable for small-scale storage facilities and farmers. Future improvements may include cloud connectivity, mobile application integration, and automated ventilation systems for enhanced grain storage management.

REFERENCES

- [1] A. Singh and R. Verma, "IoT-Based Smart Grain Storage Monitoring System," *International Journal of Engineering Research and Technology (IJERT)*, 2021.
- [2] U. Raut and S. Patil, "Smart Food Grain Storage Using Sensors," *International Journal of Innovative Research in Science, Engineering and Technology (IJIRSET)*, 2020.
- [3] P. More and R. Kharde, "Smart Agriculture Monitoring Using IoT," *IEEE Conference on IoT Applications*, 2019.
- [4] Suganda.P and Roselin M, "Smart Food Grain Storage System Using IOT," *International Journal of Innovative Research in Technology (IJIRT)*, 2026