

# Empower Her: IoT-Driven Smart Women's Safety System Using Arduino for Real-Time Protection

Prof. Shivalingappa D R<sup>#1</sup>

<sup>1</sup>Assistant Professor,

Department Of Electrical and Electronics  
Engineering.

Smt. Kamala and Sri. Venkappa M. Agadi  
College of Engineering and Technology  
Lakshmeshwar 582116,  
Karnataka, India.

Email: shivuyadav052@gmail.com

Savitha H<sup>#2</sup>

<sup>2</sup> Student,

Department Of Electrical and Electronics  
Engineering.

Smt. Kamala and Sri. Venkappa M. Agadi  
College of Engineering and Technology  
Lakshmeshwar 582116,  
Karnataka, India.

Email: savithahalbhavi@gmail.com

Suchitra K<sup>#3</sup>

<sup>3</sup> Student,

Department Of Electrical and Electronics  
Engineering.

Smt. Kamala and Sri. Venkappa M. Agadi  
College of Engineering and Technology  
Lakshmeshwar 582116,  
Karnataka, India.

Email: suchitrask14@gmail.com

Ramya P<sup>#4</sup>

<sup>4</sup> Student,

Department Of Electrical and Electronics  
Engineering.

Smt. Kamala and Sri. Venkappa M. Agadi  
College of Engineering and Technology  
Lakshmeshwar 582116,  
Karnataka, India.

Email: ramyapuranimath@gmail.com

Vani K<sup>#5</sup>

<sup>5</sup> Student,

Department Of Electrical and Electronics  
Engineering.

Smt. Kamala and Sri. Venkappa M. Agadi  
College of Engineering and Technology  
Lakshmeshwar 582116,  
Karnataka, India.

Email: vanikallimath@gmail.com

**Abstract**— Women's safety remains critical amid rising harassment cases against physically challenged women. This paper presents EmpowerHer, a wearable IoT-driven safety device using Arduino Uno that integrates GPS tracking, GSM emergency SMS alerts, ESP32-CAM live video streaming, APR33A voice distress, playback, and panic button activation. The compact wristwatch-like system sends precise GPS coordinates.

LONG 15.0995483), plays "Help!" audio, activates vibration feedback, and provides local buzzer deterrence. Hardware includes

Node MCU WiFi, NEO-6M GPS (162 dBm sensitivity), SIM900A. GSM, relay, LCD I2C display, and vibration motor. Testing confirms reliable SMS delivery, stable video streaming, and continuous system monitoring. This Arduino-based IoT solution delivers cost-effective real-time protection for women, elderly, and physically challenged individuals in urban environments

**Keywords**— IoT safety device, Arduino Uno, GPS tracking, GSM alerts, ESP32-CAM streaming, women's safety system, wearable protection, real-time emergency response.

## I. INTRODUCTION

By merging the elements of personal defense and location awareness, this device seeks to bridge the gap between personal safety and proactive response, ensuring that users can swiftly and effectively deal with emergencies while also alerting relevant parties about their situations. This paper delves into the intricacies of the Women Safety Device with Shock Taser and Location Tracking using Arduino, highlighting its key components, operational mechanisms, and the tangible benefits it brings to personal security. Through the convergence of technology and safety. Women safety has become a significant societal focus, especially in urban settings where incidents of communication functionalities. This study concentrates on incorporating essential elements, including Arduino Uno, aims to investigate the incorporation

of IOT elements to establish a resilient system capable of empowering women also a fundamental human right. Recent progress in technology, particularly within the domain of the Internet of instances of violence against women emphasize the immediate requirement for inventive solutions.

The potential of the Internet of Things to link devices and Things (IOT), has created fresh possibilities for addressing these safety concerns. The concerning data related to is possible to develop smart systems that not only react to emergencies but also offer real time monitoring and facilitate smooth communication presents a hopeful path for tackling safety issues. Through the utilization of IOT, GPS tracking, GSM900A, emergency alert systems, and a panic button, sound recognition sensor, photo capturing, shock taser, to formulate a viable solution for women's safety. The main goal of this harassment and assault are regrettably common. Safeguarding women is not only crucial for personal welfare but is conventional approaches to personal safety remain vital, they may not consistently offer prompt assistance. This paper delves into the intricacies of the Women Safety Device with Shock Taser and Location Tracking using Arduino, highlighting its key components, operational mechanisms, and the tangible benefits it brings to personal security. Through the convergence of technology and safety, this device underscores a commitment to fostering safer communities and empowering individuals to embrace their daily lives with an added layer of protection

## II. III. METHODOLOGY

### A. Hardware Components list:

1. Arduino Uno
2. Node MCU V2 WIFI MODULE
3. APR33A
4. SWITCH DEBOUNCING
5. GPS Module



B. LCD Display

1. Relay
2. ESP32-CAM
3. SIM900A GSM Modem

III. PROBLEM STATEMENT AND OBJECTIVE

A. Problem Statement:

In today's world, women's safety is a growing concern, especially in urban and semi-urban areas. Despite advancements in technology and communication, women continue to face threats such as harassment, assault, and violence, often in places where help is not immediately available.

- Traditional methods of ensuring safety, like self-defense tools or mobile applications, either require manual activation or depend on the presence of a network. These methods are not always reliable in panic situations, especially when the victim is unable to respond quickly.
- The lack of real-time tracking and automatic alert systems leaves a huge gap in women's personal security.

B. Objectives:

- To develop a smart, portable women safety device using Arduino and IOT components that can detect emergency situations in real time.
- To enable real-time location tracking using GPS technology and immediately send alerts to pre-registered emergency contacts.

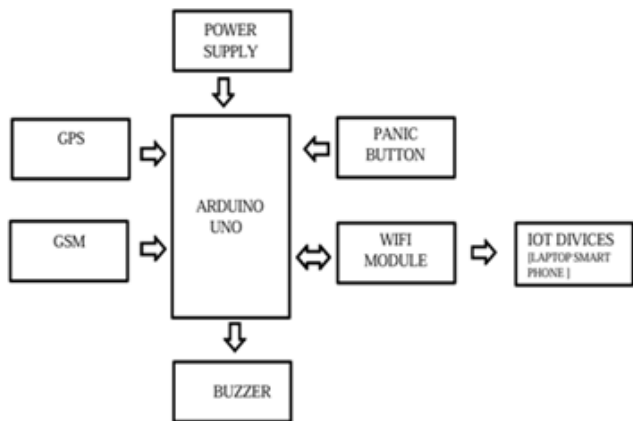

Fig. 1. Block Diagram of IOT based women's Safety System

The methodology for EmpowerHer involves a comprehensive approach to designing and developing an IoT-driven smart women's safety system using Arduino for real-time protection. This entails integrating various hardware components, including a GPS module for location tracking, a GSM module for sending alerts and notifications, accelerometers for detecting falls or sudden movements, and a panic button for sending distress signals. These components will be seamlessly integrated with the Arduino board, which will serve as the brain of the system, processing data from the sensors and triggering alerts accordingly.

The system will be programmed using the Arduino IDE, leveraging libraries and frameworks that ensure efficient data processing, GPS parsing, and GSM communication. A wearable device will be designed to house the system, ensuring that it is compact, user-friendly, and easily wearable. A cloud platform will also be utilized to store and process data, enabling remote access and analysis of system performance.

IV. RESULT AND DISCUSSION

A. Voice Play:

The Audio Alert System is a crucial part of the device's local defense strategy. It consists of a Voice Playback Module (likely an APR33A3 V2) connected to a speaker, which stores and broadcasts a pre-recorded distress message, specifically "I need help! Help!" or a loud siren. Upon activation of the Panic Button, the Arduino triggers this module, causing the speaker to emit the message loudly and repeatedly. This function works in tandem with the SMS alert, providing a necessary two-tier response by creating an immediate public signal to attract attention from bystanders and serving as a powerful local deterrent to frighten away an attacker.

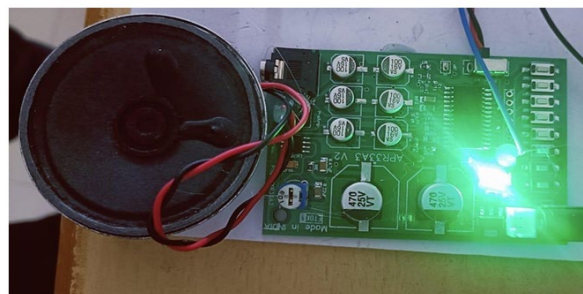

Fig. 2. Voice play

B. Live video streaming:

The ESP32-CAM module provides a critical layer of real-time visual monitoring and evidence capture for the safety device. Utilizing its integrated Wi-Fi capability and camera, the module is programmed to establish a local connection and host a live video stream, which can be instantly accessed by emergency contacts via a web link sent simultaneously with the SMS alert. This feature goes beyond basic location tracking by offering crucial visual context to the emergency, allowing responders to assess the immediate threat level and environment. Furthermore, the ability to stream and potentially record the incident ensures that valuable video evidence is captured instantly, significantly aiding in rescue efforts and subsequent investigation.

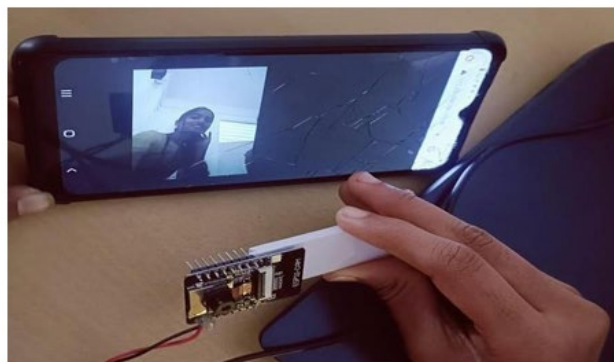

Fig. 3. Live Video Streaming

C. Alert Message:

The system validation was successfully demonstrated through two primary output mechanisms: emergency SMS alerts and continuous system logging. The first result image confirms that upon activation of the Panic Button, the GSM Module reliably sends the critical SMS alert, clearly stating 'EMERGENCY SWITCH PRESSED HELP @' followed by the precise GPS coordinates (e.g., LONG:@15.0995483, LAT:@75.3723931). This validates the core function of immediate, location-aware communication to emergency contacts. The second result image, a real-time status log captured from the system's monitoring interface, demonstrates the device's stability and continuous monitoring capability during non-emergency periods, displaying the passive state 'NO EMERGENCY SWITCH PRESSED' alongside accurate timestamps (e.g., 2025/11/19 02:02:18PM). Together, these outputs confirm the prototype's success in both rapidly communicating an emergency and maintaining dependable operational status, fulfilling the project's key safety objectives.

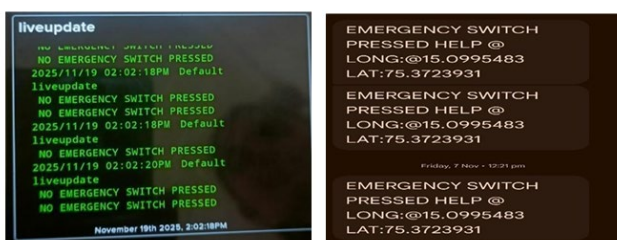

Fig. 4. Alert message

D. Proto type model:

This model represents a functional prototype of an IoT-driven Women Safety Device, utilizing the Arduino Uno as its central processing unit to manage real-time protection features. The device integrates a GPS Module to acquire the victim's precise coordinates and a GSM/GPRS Module (distinguishable by its antenna) to send immediate emergency SMS alerts containing these location details to pre-programmed contacts, effectively bridging the device to the cellular network. The system is activated by a user-friendly Panic Button, which, upon pressing, triggers two concurrent responses: the silent dispatch of the location alert and the activation of an Audio Amplifier and Speaker to emit a loud alarm, serving as a powerful local deterrent. Additionally, an LCD Display provides necessary status updates and user

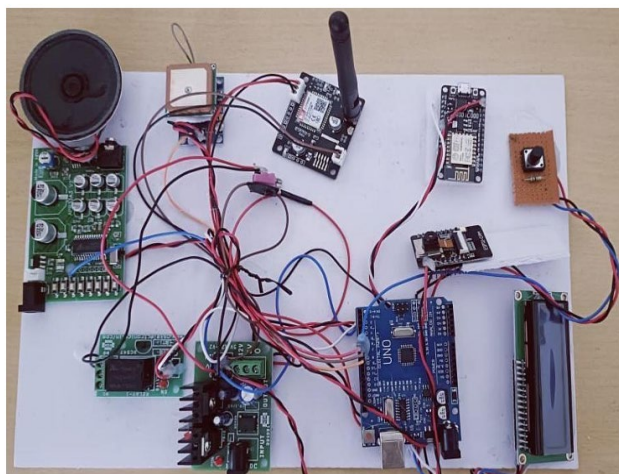

Fig. 5. Proto type model

feedback, ensuring the user knows the system is operational and the alert has been successfully transmitted.

V. ADVANTAGES DISADVANTAGES AND APPLICATIONS

A. Advantages:

1. Real-time protection
2. Personal safety
3. IoT connectivity
4. Accurate Location Tracking
5. Dual Alert Mechanism (GSM & WiFi)
6. Wearable and Discreet Design
7. Buzzer as Immediate Local Deterrent

B. Disadvantages:

1. Technical Dependence
2. False Alarm
3. Privacy Risk
4. Geographical Limitations

C. Applications:

- The concept of the safety device is primarily designed to provide security for Physically Challenged Girls.
- Specific areas where this device is highly applicable include:
  - Physically Challenged Girls: The device is conceived to provide safety to this specific group.
  - Immature Girls: This group can also benefit significantly from the device.
  - Working Physically Challenged Women or Handicaps: It is very useful for those working in large settings, such as Garment Factories.
  - Pick and Drop Company Vehicles: The device can be used in vehicles provided by companies for transport, ensuring the safety of passengers during transit.

VI. CONCLUSION

The creation and assessment of the IoT-based safety system for women, employing Arduino Uno, GPS, GSM900A, panic button, shock, laser, photo capturing, voice recording device, and buzzer, has proved promising outcomes. The effective integration of these elements illustrated the system's capability to deliver prompt and efficient responses in emergency scenarios. The manual initiation via the panic button provides users with a swift means to request assistance, and the audible feedback from the buzzer heightens situational awareness.

In summary, the IoT-based safety system for women constitutes a noteworthy progression in addressing safety issues. This initiative establishes the groundwork for the development of pragmatic and dependable solutions contributing to the creation of safer environments for society. The successful construction represents a positive step forward in utilizing technology for the enhancement of public safety.

REFERENCE

- [1] Dongare Uma, Vyavahare Vishakha and Raut Ravina, — An Android Application for Physically challenged woman or handicapes Safety Based on Voice Recognition Computing (IJCSMC) online at [www.ijcsmc.com](http://www.ijcsmc.com), Vol.4 Issue.3, pg. 216-220, March- 2015
- [2] MAGESH KUMAR.S and RAJ KUMAR.M IPROB EMERGENCY APPLICATION FOR PHYSICALLY CHALLENGED WOMAN OR HANDICAPES ISSN 2250-3153 International Journal of Scientific and Research Publications, online at the link [www.ijsrp.org](http://www.ijsrp.org) , Volume 4, Issue 3, March 2014.
- [3] Bhaskar Kamal Baishya, — Mobile Phone Embedded With Medical and Security Applications [www.iosrjournals.org](http://www.iosrjournals.org), Volume 16, Issue 3 (Version IX ), PP 30-3, May- Jun. 2014.
- [4] Dr. Sridhar Mandapati, Sravya Pamidi and Sriharitha Ambati, — A Mobile Based Physically challenged woman or handicapes Safety Application (I Safe Apps)), [www.iosrjournals.org](http://www.iosrjournals.org), Volume 17, Issue 1 (Version I), PP 29-34, Jan.-Feb. 2015.
- [5] THOYAVAN V, — ADVANCED SECURITY SYSTEM FOR PHYSICALLY CHALLENGED WOMAN OR HANDICAPES)), [www.slideshare.net](http://www.slideshare.net), Jun 24, 2014.
- [6] Prof. Basavaraj Chougula, Archana Naik, Monika Monu, Priya Patil and Priyanka Das — SMART GIRLS SECURITY SYSTEM)), [www.ijaiem.org](http://www.ijaiem.org), Volume 3, Issue 4, April 2014.
- [7] Nishant Bhardwaj and Nitish Aggarwal, —Design and Development of — Suraksha))-A Physically challenged woman or handicapes Safety Device)), <http://www.irphouse.com>, Volume 4, pp. 787-792, November 2014.
- [8] Remya George, Anjaly Cherian.V, Annet Antony, Harsha Sebastian, Mishal Antony and Rosemary Babu.T, — An Intelligent Security System for Violence against Physically challenged woman or handicapes in Public Places)), Volume-3, Issue-4, April 2014.