

Neoraksha: Smart Incubator For Preterm Infant Safety

Pratima B Kadekar¹, Megha C S², Shreedevi H³, Srishti S⁴, Sanika H⁵
Department of Electrical and Electronics Engineering,
Smt Kamala and Sri Venkappa M Agadi College of Engineering and Technology,
Laxmeshwar, Karnataka, India.

Abstract— Preterm infants are highly vulnerable to environmental fluctuations and medical complications that can arise within minutes if not continuously monitored. Neoraksha is a smart, technology-integrated incubator designed to enhance the safety, stability, and quality of care for premature neonates. This project presents the design and development of an intelligent incubator system that combines real-time physiological monitoring, environmental control, and automated alert mechanisms to support neonatal well-being.

The system incorporates sensors to track critical parameters such as temperature, humidity, heart rate, and oxygen saturation, ensuring the infant remains within clinically recommended thresholds. An embedded microcontroller processes sensor data and regulates thermal and humidity levels through a closed-loop feedback mechanism. Additionally, Neoraksha features IoT-based connectivity, enabling remote monitoring by healthcare professionals and immediate notification in case of abnormalities. A user-friendly interface provides caregivers with comprehensive, actionable insights, thereby reducing response time during emergencies.

I. INTRODUCTION

Preterm infants are among the most vulnerable patients in neonatal care, requiring continuous monitoring, precise environmental control, and rapid response to even minor changes in their physiological condition. Traditional incubators provide thermal support, but they often lack intelligent, integrated systems that can predict risks, alert caregivers in real time, and maintain optimal conditions consistently. Neoraksha, a smart incubator designed for enhanced preterm infant safety, aims to bridge this gap through the use of advanced sensors, automation, and smart analytics. By integrating real-time monitoring of vital parameters, temperature and humidity regulation, and intelligent alert mechanisms, this innovation not only supports better clinical outcomes but also reduces workload for healthcare professionals, ensuring timely interventions and improved neonatal care efficiency. Traditional incubators provide basic thermal support, but many lack intelligent monitoring, automation, and early alert features that are crucial for neonatal care especially in low-resource or rural healthcare settings.

Neo Raksha – Smart Incubator is designed to provide a safe, automated, and continuously monitored environment for premature babies. The system integrates sensors and smart controls to maintain optimal temperature, humidity, oxygen level, and light intensity. Real-time monitoring ensures that any small change in the baby's condition or incubator environment is immediately detected and corrected.

The project aims to combine IoT technology, microcontroller-based automation, and safety mechanisms to create a cost-effective and reliable solution for neonatal care.

With features like remote monitoring, automatic climate control, and alarm systems, Neo Raksha enhances the quality of care, reduces human error, and supports healthcare workers in providing timely interventions.

The Neo Raksha Smart Incubator for Infants is a technology-driven solution designed to provide a safe, affordable, and efficient neonatal care environment. This smart incubator integrates modern sensors, microcontroller-based control systems, and real-time monitoring to maintain optimal temperature, humidity, and overall safety for newborn babies.

Advancements in neonatal care emphasize the importance of automated monitoring systems that can detect early signs of distress and environmental imbalance. Safety-focused neonatal solutions aim to reduce human error, ensure consistent care, and provide real-time alerts for immediate medical response. By integrating technology with neonatal care practices, preterm infant safety can be significantly enhanced, leading to improved survival rates, reduced complications, and better long-term health outcomes.

II. LITERATURE SURVEY

Conducting a literature survey is crucial for understanding the existing research, technologies and developments in the field of smart incubator and remote safety. Here is a structured literature survey with a focus on key publications, including author descriptions and publication years.

1. Title: "Smart incubator using internet of things"

Authors: D Shivamani, Raju Rajendran J. Year: 2018
Summary: The Smart Incubator Using IoT, developed by D. Shivamani Sagayaraj and Raju Rajendaran. J, is an advanced neonatal care system designed to protect and monitor preterm infants. The incubator uses IoT technology and sensor-based automation to maintain the ideal environment required for newborn survival.

Contribution: The project Smart Incubator using IoT contributes significantly to neonatal healthcare by integrating modern automation with real-time monitoring. The authors—D. Shivamani Sagayaraj and Raju Rajendaran. J—developed a system that enhances the safety of preterm infants through continuous tracking of vital environmental parameters. Their work demonstrates how IoT can be effectively applied to create a smart, low-cost, and highly reliable incubator suitable for hospitals and remote healthcare centers.

2. Title: "Incubator temperature control"

Authors: David Ducker, A J Lyon Robert Ross Year: 2014
Summary: David Ducker, precise temperature control in neonatal incubators, as maintaining a stable thermal environment is critical for the survival and healthy development of preterm infants.



Contribution: The study by David Ducker, A. J. Lyon, and Robert Ross made important contributions to improving temperature regulation in neonatal incubators. Their work highlighted the critical relationship between controlled thermal environments and the health of preterm infants.

3. Title: “Embedded device design for incubator infant”

Authors: Dive, K Kulkarni. Year: 2021 Summary: An embedded device for incubator infant monitoring is a compact, reliable electronics system that continuously measures the baby’s physiological and micro-environmental parameters, controls the incubator actuators, alerts caregivers to abnormal conditions, and stores/transmits data for review. It pairs robust sensor inputs with real-time control, safe power management, and an intuitive user interface to keep the neonatal micro-environment stable and to support timely clinical decisions.

Contribution: Improving sensor placement and accuracy, ensuring that the incubator measures true infant micro-environment rather than misleading ambient readings. Recomending better control mechanisms, such as faster heater response and more reliable feedback systems for maintaining stable temperature

The device uses medical-grade sensors such as skin-temperature probes, ambient temperature and humidity sensors, and optional vital-parameter modules to monitor the infant and the chamber. These sensor readings are processed by the controller, which runs closed-loop algorithms—mainly PID control—to adjust heating elements, fans, and humidifiers so that the incubator remains stable around the required neonatal thermal range. The system also includes safety- critical features such as redundant sensors, alarm circuits, and automatic shut-offs to prevent overheating, sensor failure, or abnormal environmental changes. A touch screen interface allows nurses to view readings, set clinical parameters, and receive alarms, while onboard memory logs data for traceability. Power isolation, battery backup.

III. METHODOLOGY

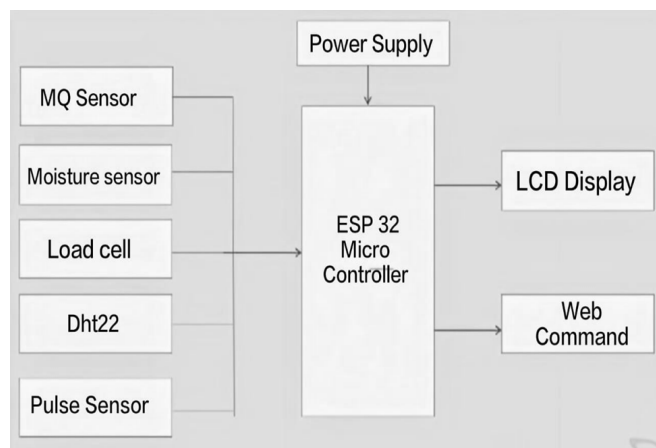

Fig. 1. Block Diagram

This block diagram represents a system controlled by an ESP32 microcontroller, which processes data from multiple sensors and interacts with outputs like an LCD display and web commands.

The proposed model consists of monitoring system which utilizes multiple sensors to measure the various parameters in incubator. The system employs an array of sensors including temperature, humidity, CO₂ (air quality), pulse, moisture, and weight sensors. Infants less than 37 weeks gestational age and/or less than 2 kg body weight must be placed in the incubator that can provide humidification within 24-48 hours of life. Humidity values for gestational age infants less than 37 weeks are in the range between 64% to94%. CO₂ sensor measures concentration of CO₂ content in the incubator. To check the baby’s growth, load cells are used to check the weight of the baby and is essentially a force transducer or force sensor. It is used to measure weight. The weight sensor (load cell) is used to monitor the baby’s growth by measuring weight variations accurately; normal readings for newborns typically range from 1000–3000 g.

The temperature sensor maintains the incubator’s internal temperature within the normal range of 36–37°C. Any deviation below or above this range is flagged as critical. The humidity sensor ensures adequate moisture levels between 64% and 94%, which is essential for premature infants to prevent dehydration and maintain skin integrity. The CO₂ sensor monitors the air quality inside the incubator, ensuring safe oxygen levels for the infant. The pulse sensor tracks the heart rate of the baby, with readings typically within the range of ADC, all these parameters are displayed on a real-time web-based dashboard, which categorizes each reading as Critical, Normal, or Good based on predefined thresholds.

A. Components used

1) LCD with i2C



Fig. 2. LCD with i2C

Display format: 16 characters x 2 lines Character size: 5 x 8 dot matrix Operating voltage: 5V DC

An LCD (Liquid Crystal Display) with I2C interface is widely used in embedded systems for displaying characters, sensor values, and status messages. Traditional 16×2 or 20×4character LCD modules normally require multiple digital pins for data and control signals (usually 8–12 pins). This can be a limitation when working with microcontrollers that have a limited number of GPIO pins. To overcome this, an I2C (Inter-Integrated Circuit) communication module is attached to the LCD, reducing the required connections to only two signal lines—SDA (data) and SCL (clock)—along with power (VCC and GND). With this interface, the LCD becomes more efficient, easier to integrate, and more suitable for compact or multi-sensor projects.

B. ESP 32 Microcontroller

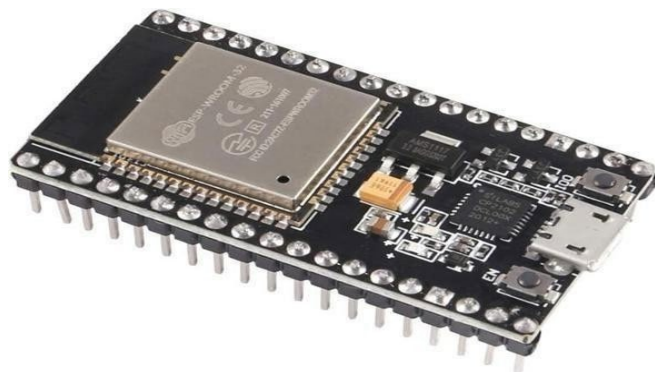

Fig. 3. ESP 32 Microcontroller

Type: WiFi + Bluetooth microcontroller Clock speed: up to 240MHZ

Flash: 4 MB (varies)

Supports: ADC, PWM, 12C, SPI, UART

Power: 3.3V

The ESP32 is a powerful, low-cost, and energy-efficient microcontroller developed by Espressif Systems. It is widely used in modern embedded and IoT applications due to its integrated Wi-Fi, Bluetooth, high processing speed, and rich set of peripherals. Its versatility makes it ideal for real-time monitoring systems such as smart incubators, where continuous data acquisition, wireless communication, and efficient processing are essential. The ESP32 follows an SoC model in which the central processing unit, memory blocks, communication modules, input/output interfaces, and security hardware are integrated on a single silicon die. This increases processing efficiency, reduces latency, and minimizes power consumption.

C. Load Cell

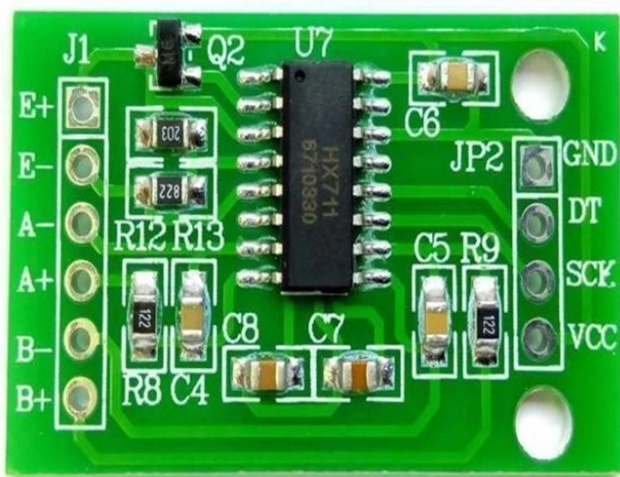

Fig. 4. Transistor BC547

Type: Strain Gauge + ADC module Load Cell: 1Kg/ 5kg/ 10Kg(as used)

Output: millivolt signal

H X 711 resolution: 24-bit Voltage: 3.3-5V

A load cell is an electromechanical transducer that converts an applied mechanical force into a measurable electrical signal. Its operation is based on the principle of strain measurement, in which a metallic structure undergoes minute deformation when subjected to weight, tension, compression, or pressure. This deformation is extremely small and cannot be observed visually, but it is sufficient to alter the electrical resistance of strain gauges that are bonded to the surface of the load cell body. A strain gauge is a thin metallic foil arranged in a grid pattern, and when the load cell is compressed or stretched, the strain gauge also stretches or compresses. This change in shape leads to a proportional change in its electrical resistance. Since the resistance change is extremely small, it is detected by connecting the strain gauges in a Wheatstone bridge configuration. In a typical load cell, four strain gauges are arranged in such a way that two gauges experience tension while the other two experience compression

D. Moisture Sensor

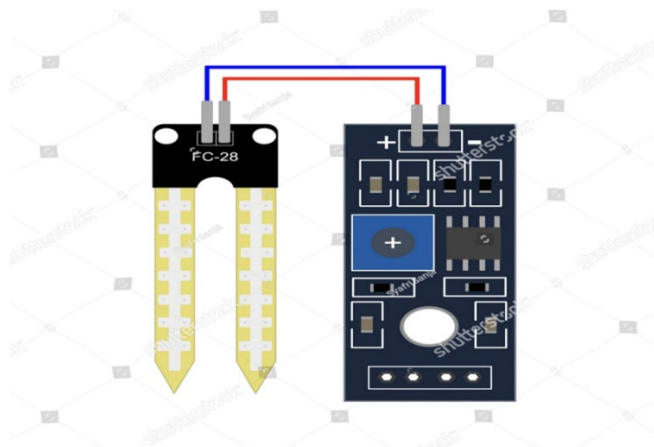

Fig. 5. Moisture Sensor

Voltage: 3.3-5V

Output: analog (moisture level) Detection of wetness

A moisture sensor is a device designed to determine how much water is present in a given environment or material. Its fundamental principle is based on the fact that water alters certain physical properties—such as electrical resistance, capacitance, or tension—in a predictable way. By detecting these changes, the sensor can infer the amount of moisture present.

In soil applications, the sensor interacts directly with the ground and measures how easily electricity moves through it or how the soil's dielectric properties change. Wetter soil conducts electricity more easily and has a higher dielectric constant, while dry soil resists electrical flow and shows lower dielectric values. Some advanced sensors measure the tension with which water is held in the soil, representing how accessible the water is to plants.

E. MQ Sensor (Gas Sensor)



Fig. 6. MQ Sensor (Gas Sensor)

Type: gas sensor

Detects CO₂, smoke, LPG Voltage: 5V

Output: analog and digital Warm up time: ~ 20 sec

An MQ sensor is a gas-sensing device that operates on the principle that certain gases change the electrical conductivity of a heated semiconductor material. At its core, the sensor contains a sensitive layer—typically tin dioxide—that has low conductivity in clean air. When the sensor is exposed to a target gas such as methane, carbon monoxide, alcohol vapor, or smoke (depending on the MQ model), the gas molecules interact with the surface of the semiconductor. This interaction alters the number of charge carriers available within the material, effectively changing its resistance.

To maintain sensitivity, the sensing element is kept at a specific high temperature using an internal heater coil. This heat activates the chemical and physical processes on the surface, allowing the gas molecules to adsorb and react. As gases contact the heated surface, they either donate or capture electrons, shifting the resistance in a measurable way.

F. DHT22 (Temperature Sensor)



Fig. 7. DHT22 (Temperature Sensor)

Operating voltage: 3.3V-5V Temperature range: 0- 50C
Humidity: 20-90%

Sampling rate: 1HZ (1 reading/ second) Output: digital (single- wire protocol)

The DHT22 is a digital temperature and humidity sensor that works by converting physical changes in its sensing materials into electrical signals and then packaging those signals into a calibrated digital output. For temperature measurement, it uses a thermistor-like element whose electrical resistance shifts predictably with changes in temperature. Inside the sensor, an integrated circuit continually monitors this resistance and translates it into a precise temperature value. For humidity, the device relies on a capacitive sensing element made of a polymer film that absorbs moisture from the air; as the amount of absorbed water changes, the film's dielectric properties shift, altering the capacitance.

G. Pulse Sensor



Fig. 8. Pulse sensor

Operating voltage: 3.3-5V Current consumption: 4-6mA
Output type- analog

A pulse sensor works by detecting the tiny fluctuations in blood volume that occur each time the heart beats. It typically uses a light-based method called photoplethysmography, where an LED shines light into the skin and a photo detector measures how much of that light is reflected or absorbed. When the heart pumps, blood momentarily fills the capillaries more densely, causing a slight increase in light absorption; between beats, the blood volume decreases and more light is reflected. These rhythmic changes in light intensity are extremely small, so the sensor's circuitry amplifies and filters the signal to isolate the repeating waveform created by the heartbeat. As the light variations correspond directly to the expansion and contraction of blood vessels, the processed signal reveals the pulse pattern. The output can then be analyzed to determine heart rate and, in some cases, the quality or regularity of the heartbeat.

- Smart Cook's innovative working model seamlessly integrates mobile technology with cooking appliances.
- Users download the mobile app, pair it with Wi-Fi/Bluetooth-enabled appliances, and select recipes with customized cooking parameters.

IV. ADVANTAGES AND DISADVANTAGES

A. Advantages

Advantages of the Neoraksha: Smart incubator for preterm infant safety.

1. The system provides continuous and reliable monitoring of preterm infants, ensuring their vital signs are always tracked.
2. It helps in the early detection of health risks by identifying abnormal changes in temperature, humidity, pulse, or environment.
3. The incubator maintains enhanced environmental control, creating a safe and stable atmosphere for infant growth.
4. It reduces the workload for nurses and caregivers by automating routine monitoring tasks.
5. The system enables faster emergency response by generating instant alerts during critical conditions.
6. Remote monitoring allows doctors and caregivers to supervise infant conditions in real time from any location.
7. The design is low-cost and energy-efficient, making it accessible for healthcare centers with limited resources.
8. A user-friendly interface ensures that even non-technical staff can easily interpret the readings and alerts.
9. Multi-sensor integration improves accuracy and provides a more comprehensive understanding of the infant's condition.

B. Disadvantages

1. The system depends heavily on sensors, which may give inaccurate readings if they malfunction or drift over time.
2. Continuous operation of multiple sensors and communication modules increases power consumption.
3. Internet-based monitoring can face issues like connectivity drops or delays in data transmission.
4. The setup requires regular calibration and maintenance to ensure reliable performance.
5. Technical faults in the microcontroller or electronics could disrupt monitoring and compromise safety.

V. CONCLUSION

The Neoraksha: Smart Incubator for Preterm Infant Safety project demonstrates a practical and innovative approach to improving neonatal care by integrating advanced sensing, monitoring, and IoT technology into a single, affordable system. Through the combined use of temperature–humidity sensors, pulse sensors, moisture detectors, gas sensors, and a load cell, the incubator provides a comprehensive understanding of an infant's environment and physiological condition. The ESP32 microcontroller serves as the intelligent core, processing data in real time and ensuring that caregivers receive immediate alerts whenever conditions deviate from safe limits. By offering both local LCD display feedback and remote web-based monitoring, the project enhances accessibility and allows medical staff and parents to stay informed even from a distance. This dual-layer safety mechanism helps reduce reaction time during emergencies and supports more consistent and accurate monitoring than manual methods. Moreover, its low-cost design makes it highly suitable for rural clinics, resource-limited hospitals, and home-care scenarios.

Overall, the Neoraksha system proves that integrating low-cost electronics with smart monitoring can significantly elevate the quality of care for preterm infants. It provides a safer environment, minimizes human error, and contributes meaningfully to infant survival and wellbeing. The project stands as a valuable step toward modernizing neonatal incubation systems and sets the foundation for further advancements in smart healthcare technology.

REFERENCES

- [1] "Smart Incubator Using Internet of things" by D Shivamani Sagayaraj Raju Rajendra J., published in the international journal for modern trends in science and technology (2018).
- [2] "An Incubator Controls And maintains The Babys Body Temperature" by David ducker, A J Lyon Robert Ross., published in the archives of disease in childhood (2014).
- [3] "An embedded device monitors and controls incubator conditions to keep infants safe and stable" by Dive, K Kulkarni., published in the Journal of Advanced Research in Computer Science and Engineering (2013).
- [4] Karuppasamy, P., & Athimoolam, S. (2022). Smart Incubator for Premature Baby in an IoT Application. Journal of Semiconductor Devices and Circuits, Vol. 9, No. 2.
- [5] Gowri Shankar, J., Risitha, K., Revathi, M., Saranya, M., & Priyadarshini, M. (2023). Design and Implementation of Newborns Neonatal Intensive Care Unit for Premature Infant Based on IoT. IJERT, Vol. 11, Issue 03.
- [6] HN, S., Patil, S., Sannakki, S., Guruvini, V., & S, A. (2021). Development of Incubation System for Premature Baby Care. Asian Journal For Convergence In Technology (AJCT). DOI: 10.33130/AJCT.2021v07i02.017.
- [7] Eniyaa, P. P., Jeya Pragathi, R. S., Kalki, V., Monica, S. T., & Nithya, C. (2023). An Intelligent System for Infant Incubator Using the IoMT. Journal for ReAttach Therapy and Developmental Diversities, 6(10s), 2129–2135. DOI: 10.53555/jrtdd.v6i10s.2830