

Lora Based Wireless Post Border Security System

Keshav Negalur¹
Electrical and Electronics
Engineering Deptment
SKSVMACET,
Lakshmeshwar
VTU, Belagavi
keshrash@gmail.com

Saniya Ritti²
Electrical and Electronics
Engineering Deptment
SKSVMACET,
Lakshmeshwar
VTU, Belagavi
saniyaritti@gmail.com

Ratna Kshatriya³
Electrical and Electronics
Engineering Deptment
SKSVMACET,
Lakshmeshwar
VTU, Belagavi
ratnakshatriya8@gmail.com

Pavankumar M Purad⁴
Electrical and Electronics
Engineering Deptment
SKSVMACET,
Lakshmeshwar
VTU, Belagavi
mppavankumar17@gmail.com

Bharatgouda Ugalat⁵
Electrical and Electronics
Engineering Deptment
SKSVMACET,
Lakshmeshwar
VTU, Belagavi
bharatugalat222@gmail.com

Abstract—The Border surveillance is the most difficult and important task for national defense and security. Especially under certain circumstances when activities like terrorists' infiltrations, intrusions and illegal happenings between the borders, it has become utmost important to protect the borders with smart and advance technology. Our project is based on a Border security system which fabricates on border security, by using advance technologies. The main objective of the paper is to describe how the technologies used in this system works and how this will help the soldiers to secure the border of the country. To curb such happenings the least we can do is to constantly monitor across the border and detect intrusions. It takes a lot of man power to stretch over the border and constantly keep an eye, hence the need of the hour is to build such automated border surveillance which can eliminate man power. Moreover, if something suspicious is detected by the system, it must be able to perform necessary actions by issuing an alarm alert and weapon activation system. The central room can be set up within a distance from the border. Once the human controller is aware of intrusion it is upon them to take next course of action.

Keywords— Border surveillance system, national security, intrusion detection, automated border monitoring, ultrasonic sensor, motion detection, wireless communication, alarm system, defense technology, smart security system, border protection, surveillance automation, security alert system, IoT-based monitoring.

I. INTRODUCTION

Security and surveillance have become crucial in the modern era due to the increasing risks of unauthorized access, intrusions, and security breaches in sensitive zones such as borders, defense areas, industries, and restricted premises. Traditional systems like CCTV cameras and manual patrolling have several limitations, including short communication range, dependency on human monitoring, high installation cost, and susceptibility to human error. Hence, there is a strong demand for an automated, intelligent, and long-range security system that can detect and alert in real-time. In recent years, the advancement of Internet of Things (IoT), wireless sensor networks, and embedded systems has enabled the development of smart surveillance systems. Among different wireless technologies, LoRa (Long Range) has gained popularity because of its low power consumption, long communication range, low cost, and reliable data transfer. This makes it ideal for applications

such as border security, rural monitoring, and large-scale surveillance where conventional wireless systems fail. This project proposes the design and development of a LoRa-based intrusion detection and alert system using Arduino microcontrollers and multiple sensors like PIR sensors (to detect human movement), laser sensors (to detect object crossing), and metal detectors (to identify metallic objects). The sensor data is processed by Arduino and transmitted wirelessly through LoRa modules to a gateway and receiver node. At the receiver side, the system provides instant alerts by triggering a siren and displaying real-time status on an LCD screen. The main advantages of this system are its low cost, low power requirement, scalability, and ability to operate in remote and wide-area locations. Such a system can play a vital role in applications like border security, defense monitoring, restricted area surveillance, and smart city safety systems.

II. INTRODUCTION TO LORA TECHNOLOGY

The IoT industry is bringing lots of technology and solutions to the market with chip manufacturers investing heavily in the market growing the industry exponentially. It isn't however without its challenges. One of the key challenges in building out the internet of things is ensuring that those "things" or end nodes are in fact able to communicate with the internet. The sheer number of current internet devices is massive and is expected to hit 25 billion by 2020. Any network that supports such an infrastructure needs to have the ability to handle the traffic. These issues don't include the fact that nodes need to run on some sort of battery power, have weak radios and also are limited in memory and processing power. IoT devices today use a number of different technologies to support their communications, but none of them are really ideal for the purpose and application of today. Wi-Fi is everywhere at the moment but it uses a lot of energy and transmits lots of data, whilst this is great it isn't such a perfect solution for IoT devices that don't have as much energy at their disposal or wish to send small amounts of data. There are also limitations in the modulation techniques used and as such access points can only handle a handful of devices at once. Bluetooth devices allow local communication but has very limited range in version 4.0. They also require too much power. Even newer Bluetooth Low Energy devices still consume much more power than is necessary. Up to recently



the best available technology on the market was considered to be ZigBee low power modules that transmit over greater distances and at low transfer rates, usually a few kilometers in clear path. What is LoRa? LoRa technology was developed by a company called Semtech and it is a new wireless protocol designed specifically for long-range, low-power communications. LoRa stands for Long Range Radio and is mainly targeted for M2M and IoT networks. This technology will enable public or multi-tenant networks to connect a number of applications running on the same network. LoRa Alliance was formed to standardize LPWAN (Low Power Wide Area Networks) for IoT and is a non-profit association which features membership from a number of key market shareholders such as CISCO, actility, Micro Chip, IBM, STMICRO, SEMTECH, Orange mobile and many more. This alliance is key to providing interoperability among multiple nationwide networks. Each LoRa gateway has the ability to handle up to millions of nodes. The signals can span a significant distance, which means that there is less infrastructure required, making constructing a network much cheaper and faster to implement.

III. OBJECTIVES

1. To detect human movement using PIR sensors.
2. To identify metallic objects with a metal sensor.
3. To sense object crossing using laser decoder.
4. To process and display detection data on Arduino with LCD.
5. To transmit information over long distances using LoRa communication.
6. To trigger alerts through siren and LCD at the receiver side for security.

IV. LITERATURE SURVEY

1. Surveillance Robot Using Raspberry Pi for Home Security Purposes. Authors: Gaurav S. Bagul et al., Shubham Mittal, Jayendra Kumar Rai, Ashish U, Bokade, V.R. Ratnaparkhe, Kaur, and DilipKumar. Year:2018.

Description: This research focuses on IoT-based surveillance robots using Raspberry Pi for home and defense security. The robots are designed to provide real-time video streaming, intruder detection, face recognition, obstacle avoidance, and hazardous gas detection. Controlled through Wi-Fi, Android applications, or autonomous mechanisms, these robots can operate in hazardous or remote environments, replacing human involvement. Different models integrate PIR sensors, cameras, servo motors, and wireless communication to ensure cost-effective, reliable, and continuous surveillance for both household and military applications.

2. Raspberry Pi Controlled Night Vision Patrolling Robot Authors: J. N. Amrutha and K. R. Rekha. Year: 2020.

Description: This project presents an IoT-based night vision patrolling robot controlled using Raspberry Pi, designed to provide autonomous and wireless surveillance in hazardous or sensitive areas. The robot is equipped with night vision cameras, sound sensors, GSM, and MCU

modules, enabling it to patrol a predefined path, detect suspicious sounds, capture 360° images, and transmit them in real time to the user via IoT Gecko and Blynk applications. It automatically responds to sound signals by rotating its HD camera, scanning the area, detecting intruders or human faces, and sending alerts through images, emails, or notifications. The system is designed for industrial zones, military areas, hospitals, shopping malls, national events, and women’s safety applications, where constant monitoring is essential. By combining IoT, Python programming, and Raspberry Pi’s processing capabilities, the robot provides cost-effective, autonomous, and real-time surveillance to safeguard people and property in diverse environments.

3. Raspberry Pi Based Intelligent Robot for Military Applications. Authors: S. A. Joshi, Aparna Tondarkar, Krishna Solanke, Rohit Jagtap Year:2018

Description: This work proposes the design of a Raspberry Pi-based intelligent robot for military applications to minimize the risk to human soldiers during hazardous operations. Military robots are employed to handle dangerous jobs such as surveillance of enemy bases, border monitoring, and detection of hidden chemical objects using gas sensors. The system integrates Raspberry Pi with Raspbian OS, supporting multiple programming languages like Python, along with sensors for gas detection and a high-resolution camera for real-time monitoring. Compact in size, the robot can be deployed in enemy territories for spying, tracking movements, and securing borders. This mechanism reduces human involvement in risky tasks and helps prevent the loss of lives, providing an efficient and reliable solution for modern military applications.

V. METHODOLOGY

Block Diagram

Transmitter Node

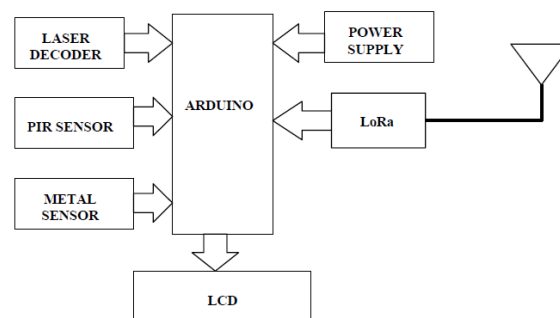

Fig. 1. Transmitter Node

Gate Way

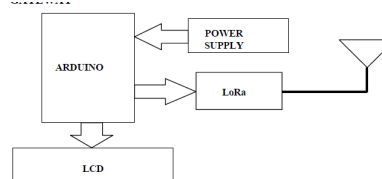

Fig. 2. Gate Way

Receiver Node

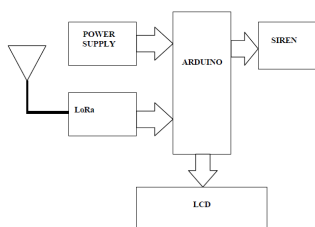

Fig. 3. Receiver Node

The LoRa-based wireless post border security system works by continuously monitoring the border area using a combination of sensors and long-range communication technology. At the border post, three sensing units—a laser decoder, a PIR motion sensor, and a metal detector—are connected to an Arduino controller. Each sensor performs a different security function: the laser decoder identifies any interruption of the laser beam, the PIR sensor detects human movement within the restricted zone, and the metal sensor identifies the presence of weapons or metallic objects. Whenever any of these sensors detect unusual activity, they send signals to the Arduino, which processes the input and converts it into meaningful alert data. This information is then transmitted over long distances using a LoRa module, which offers reliable communication even in remote border regions. An LCD display at the transmitter node shows the real-time status of each sensor and helps in local monitoring. The transmitted data is then received at the gateway unit. This gateway also consists of an Arduino and a LoRa receiver, which captures the alert sent from the border post. The Arduino in the gateway interprets the received information and displays the corresponding alert message on an LCD screen. This ensures that the monitoring team stationed at the gateway is immediately updated about any activity taking place at the post. If required, the gateway further forwards the alert to the final security station. In the final receiver and alarm unit, another LoRa module receives signals from the gateway. Here, the Arduino activates a siren or alarm whenever an intrusion is detected. The LCD at this unit shows the type of alert—for example, “Laser Breach,” “Motion Detected,” or “Metal Detected”—allowing security personnel to quickly assess the situation. The triggered siren provides an instant sound warning, enabling faster response during emergencies. Through this integrated setup, the system ensures long-range, low-power, and real-time monitoring of border posts, making it a reliable and effective solution for remote security surveillance. The template is used to format your paper and style the text. All margins, column widths, line spaces, and text fonts are prescribed; please do not alter them. You may note peculiarities. For example, the head margin in this template measures proportionately more than is customary. This measurement and others are deliberate, using specifications that anticipate your paper as one part of the entire proceedings, and not as an independent document. Please do not revise any of the current designations.

VI. RESULT

Outcomes

1. **Enhanced National Security:** Prevents illegal crossings, smuggling, and infiltration. Detects and intercepts potential threats before they enter the country.

2. **Efficient Monitoring & Surveillance:** Uses technologies like drones, sensors, radars, and CCTV to monitor border areas continuously. Enables real-time tracking and quick response to suspicious activities.
3. **Prevention of Illegal Activities:** Reduces smuggling of drugs, weapons, and contraband. Helps control human trafficking and illegal migration.
4. **Strengthened Law Enforcement:** Improves coordination between border security forces and other law enforcement agencies. Supports evidence collection for legal actions.
5. **Cost-Effective Resource Management:** Reduces manpower needs with automated surveillance systems. Lowers operational costs by deploying energy-efficient systems like solar-powered sensors. Optimizes patrolling schedules using data-driven analytics.
6. **Accurate Intrusion Detection:** Laser sensors create invisible boundaries and immediately detect any crossing or cutting attempts. NPIR sensors detect human or animal movement based on body heat. Metal detectors identify weapons or smuggled metallic objects quick.

Working Model



Fig. 4. Working Model

The proposed border security system uses Arduino, LoRa modules, and various sensors to enhance border safety by detecting unauthorized activities. The transmitter node is equipped with a PIR sensor to detect motion, a laser decoder to monitor boundary crossings, and a metal sensor to identify weapons or metallic objects. The Arduino processes the sensor data and displays the status on an LCD screen. Using a LoRa module, the collected data is transmitted wirelessly over long distances to the gateway node, which acts as a bridge and forwards the information to the receiver node. At the receiver node, the Arduino displays alerts on the LCD and activates a siren in case of intrusions or suspicious activities, enabling real-time monitoring and quick response by security personnel.

ADVANTAGES

1. **Border Surveillance:** This system is highly effective for monitoring international borders where continuous human patrolling is challenging. The sensors detect any unauthorized movement, weapon presence, or boundary crossing, and the long-range LoRa communication instantly alerts the control room. This helps security forces respond quickly and prevent illegal entry or smuggling activities.

2. **Military Camps & Defense Zones:** Restricted military areas require tight security. This system provides automatic intrusion detection within the camp premises. If any suspicious movement or metal object is detected, the alert is sent immediately to security personnel, ensuring safety of sensitive zones and preventing unauthorized access.
3. **Watch Towers & Remote Outposts:** Remote military outposts and watch towers are often far apart from each other. LoRa enables communication over several kilometers without the need for complex infrastructure. Guards stationed in such areas can receive real-time alerts from different posts, increasing situational awareness and coordination.
4. **Forest Border Protection:** Forest boundaries often face issues like illegal logging, wildlife poaching, or human intrusion. The sensors can detect movement or metal objects, helping forest officials track suspicious activities. Even wild animal movement near restricted areas can be monitored to ensure safety and prevent human–animal conflicts.
5. **Critical Infrastructure Security:** Important installations like dams, power stations, substations, research laboratories, and water treatment plants need constant protection. The system helps detect unauthorized entry and prevents potential sabotage. Its wireless long-range capability makes it ideal for securing large and sensitive zones.
6. **Industrial Perimeter Monitoring:** Large industrial facilities and warehouses require perimeter surveillance to prevent theft, sabotage, and unauthorized access. The LoRa-based security setup can cover wide industrial areas without expensive wiring. Any breach in the perimeter triggers immediate alerts for security staff.
7. **Remote Area Surveillance:** In regions where human patrolling is difficult—such as hilly areas, deserts, border villages, or farmlands—this system works reliably. Since LoRa consumes very low power and covers long distances, it continuously monitors the area and keeps security teams updated even in isolated locations.
8. **Disaster-Prone or Isolated Regions:** During natural disasters like floods, landslides, or storms, traditional communication systems often fail. LoRa-based systems continue working due to their low power and long-range capability. They help monitor movement in sensitive regions, secure temporary military camps, and ensure the safety of rescue teams and equipment.

DISADVANTAGES

1. **Limited Data Bandwidth:** LoRa can transmit only small packets of data, which means it cannot send images or videos. This limits the system to basic alerts, making it unsuitable for applications that require visual confirmation of intruders.
2. **Delayed Data Transmission:** LoRa works at low data rates, so there can be slight delays in sending or receiving alerts. In security applications where

immediate response is needed, even small delays can affect the effectiveness of the system.

3. **Susceptible to Interference:** Because LoRa operates in unlicensed radio frequencies, nearby devices using similar frequencies may cause interference. This can weaken the signal and reduce the reliability of communication in certain environments.
4. **False Alarms Due to Environmental Factors:** Sensors like PIR, lasers, and metal detectors can sometimes be triggered by wind, animals, or temperature changes. This may cause unnecessary alerts, requiring regular calibration and maintenance.
5. **Power Dependency:** The sensors and LoRa modules need constant power to operate. In remote border areas, maintaining power—especially when using batteries—can be challenging and may lead to downtime if not monitored.

APPLICATIONS

1. **Railway Track and Tunnel Security:** The system can be installed along railway tracks, tunnels, and bridges to detect unauthorized access or suspicious movement. This helps railway authorities prevent accidents, sabotage, and trespassing in sensitive zones.
2. **Airport Perimeter Monitoring:** Airports have large boundary areas that require constant surveillance. LoRa sensors can detect human or vehicle movement near restricted airport zones and immediately notify security teams to respond quickly.
3. **Solar Farms and Wind Energy Plants:** Renewable energy installations are usually spread across vast open lands. The system helps protect solar panels, turbines, and equipment from theft or tampering by detecting intrusions and sending alerts even from remote edges.
4. **Agricultural and Farm Land Security:** Farmers can use the system to safeguard large fields, especially at night. It can detect animal entry, human trespassing, or theft of tools and equipment, helping farmers respond before crops or property are damaged.
5. **Mining Areas and Quarries:** Mining locations often have restricted zones for safety. LoRa sensors can monitor movement around pits, tunnels, and machinery areas, reducing accidents and controlling unauthorized entry.
6. **Smart City Public Safety Zones :** In smart city setups, LoRa devices can be used in public parks, lakesides, and isolated pathways to detect unusual activity and improve citizen safety, especially during night hours.
7. **Border Village Protection:** Villages very close to border areas often experience wildlife entry or unknown movement at night. This system can help villagers get early warnings and stay safe.
8. **Construction Site Security:** Construction areas are often left unattended at night. The system helps detect entry of unknown persons, preventing theft of materials, tools, or machinery.

VII. CONCLUSION

This project presents a low-cost and reliable intrusion detection system using Arduino and LoRa communication. With the integration of PIR, laser, and metal sensors, it can effectively detect unauthorized movements and transmit alerts over long distances. The system provides instant notification through siren and LCD, making it suitable for border security, restricted areas, and remote surveillance. It is power-efficient, scalable, and reduces human dependency, offering a practical solution for modern security needs.

VIII. FUTURE SCOPE

The future scope of the LoRa-based wireless post border security system is broad, with immense potential for technological upgrades that can make border surveillance smarter, faster, and more reliable. In the future, the system can incorporate advanced AI algorithms to analyze intrusion patterns, learn from past events, and automatically differentiate between human movement, animals, or environmental disturbances, reducing false alarms to a minimum. Integration of high-resolution thermal and infrared cameras will allow continuous monitoring even in complete darkness, fog, or harsh weather conditions. The addition of GPS-enabled tracking devices can help authorities trace intruder movement and send real-time coordinates to patrolling teams. The system can also be expanded into a multi-node LoRa mesh network, enabling thousands of sensors to work together to secure long stretches of border terrain seamlessly. Further, the entire system can be powered by renewable energy sources like solar panels, making it self-sufficient and capable of operating in remote areas without maintenance. Cloud-based dashboards and IoT platforms can be added to allow centralized monitoring from command centers, while mobile apps can provide instant notifications to field officers. Future

versions may even include drone integration for automatic aerial verification whenever an alert is triggered. Altogether, these advancements will transform the system into a highly intelligent, automated, and scalable border security solution suitable for future defense requirements

REFERENCES

- [1] Chindhia.P, J. Jayaseelan.J, Dr. Gandhimathi.G, (2018) "Smart Engine Based Border Alert and Security System for Fishermen", International Research Journal of Engineering and Technology (IRJET), volume 5, issue 4.
- [2] Ms. Devkar A. R, Ms. Mulik D.D , Ms. Saste P.R, Mr. Ranaware A.A, (2016) "GSM & PIR Based Advanced Antitheft Security System", International Journal for Research in Applied Science & Engineering Technology (IJRASET), volume 4, issue 3, ISSN: 2321-9653.
- [3] Emad Felemban, (2013) "Advanced Border Intrusion Detection and Surveillance Using Wireless Sensor Network Technology," International Journal of Communications, Network and System Sciences, volume 6, pp. 251-259.
- [4] Essendorfer.B, Monari.E and Wanning.H, (2009) "An Integrated System for Border Surveillance", IEE Fourth International Conference on Systems (ICONS 09).
- [5] Naveen Kumar.M, Ranjith.R, (2014) "Border alert and smart tracking system with alarm using DGPS and GSM", International Journal of Emerging Technology in Computer Science & Electronics (IJETCSE) ISSN: 0976- 1353, volume 8, issue 1.
- [6] Pampapathi B.S and Manjunath P.C, (2016) "Intrusion Detection using Passive Infrared Sensor (PIR)", Asian Journal of Engineering Technology and Innovation, volume 4, issue 7, pp. 134- 139.
- [7] Sathishkumar.M, Rajini.S, (2015) "Smart Surveillance System Using PIR Sensor Network and GSM" International Journal of Advanced Research in Computer Engineering and Technology (IJARCET), volume 4, issue 1, ISSN: 2278 – 1323.
- [8] Tamilselvan.K.S and Balakumaran.T, (2012) "Smart Security System Using Embedded System Technology" International Journal of Advanced Research in Electronics and Communication Engineering (IJARECE), volume 1, issue 6.